

 euro appliances



ovens



cooktops



rangehoods















dishwashers

www.euroappliances.com.au

bringing the best of Italian quality to Australia

EEF90MSS

LEGEND FOR ALL OVEN FUNCTIONS

-  oven light
-  defrost
-  fan cooking
-  fan grilling
-  full grill
-  half grill
-  top + bottom element
-  bottom element
-  top element
-  conventional cooking + fan
-  top element + fan
-  bottom element + fan
-  fan, back, top + grill elements
-  fan, back + top elements



- 
- 
- 
- 
- 
- 
- 
- 
- 
- 

Elegance

90cm freestanding oven

- + Eight function multi-oven
- + Five burners including fish & wok burner
- + Cast iron trivets
- + Digital programmable clock
- + Plate warming drawer
- + Flame failure device
- + Cavity Cooling System
- + One touch electric ignition
- + LPG jets included
- + Height adjustable legs
- + Stainless steel kicker plate included
- + Chrome wire wok support included

| Burner | MJ/HR |
|--------------|-------|
| Rapid Burner | 10.8 |
| Semi Rapid | 6.3 |
| Auxiliary | 3.6 |
| Wok Burner | 11.9 |
| Fish | 10.8 |



Nova

60cm freestanding oven



- + Eight function multi-oven
- + Four burners including wok burner
- + Cast iron trivets
- + Digital programmable clock
- + Usable volume 61 Litre
- + Plate warming drawer
- + Flame failure device
- + Cavity Cooling System
- + One touch electric ignition
- + LPG jets included



| Burner | MJ/HR |
|--------------|-------|
| Semi Quick | 7.1 |
| Auxiliary | 3.9 |
| Triple Crown | 13.9 |



EFS60MSS



Nova

90cm freestanding oven



- + Eight function multi-oven
- + Five burners including centre wok burner
- + Cast iron trivets
- + Digital programmable clock
- + Usable volume 105 Litre
- + Plate warming drawer
- + Triple glazed glass door
- + Flame failure device
- + Cavity Cooling System
- + One touch electric ignition
- + LPG jets included
- + Height adjustable legs



| Burner | MJ/HR |
|--------------|-------|
| Auxiliary | 4.0 |
| Semi Quick | 7.1 |
| Quick | 11.0 |
| Triple Crown | 12.5 |



ENF90BSS



freestanding ovens

E0SGSS



Double oven series



Fanned oven



- + Light
- + Defrost
- + Fan-forced cooking
- + 52Lt capacity



Upper oven



- + Light
- + Large grill
- + 30Lt capacity

Features

- + Electronic timer
- + Fan motor

Available in Stainless Steel

EDOMSS



Multifunction oven



- + Light
- + Defrost
- + Conventional cooking
- + Fan-forced cooking
- + Centre/Large/Fan grill
- + Fan-assisted baking
- + 52Lt capacity



Upper static oven



- + Light
- + Bottom/Top element
- + Conventional oven
- + Centre grill
- + 30Lt capacity



Features

- + Electronic timer
- + Fan motor
- + Cooling fan
- + Drop down element



Available in Stainless Steel

E90MSS



Underbench oven 90cm series



- + Eight function Multi-oven
- + Digital programmable clock
- + Triple glazed glass door
- + Cavity cooling system
- + Centre/Large/Fan grill
- + Rotisserie



Available in Stainless Steel



Electric oven series



Fanforced EF60 series



- + 120 minute cut out timer
- + Four function oven
- + Total usable volume 57LT
- + Closed door grilling
- + Cavity cooling system
- + Double glazed door
- + Easy clean baking tray
- + Grill rack and grill handle
- + Oven indicator light
- + Easy wipe clean stainless steel

Available in Stainless Steel and White



EF60SS

EF60WH



Professional EP60 series



- + 'End Cooking' digital clock
- + Total usable volume 57LT
- + Closed door grilling
- + Cavity cooling system
- + Double glazed door
- + Easy clean baking tray
- + Grill rack and grill handle
- + Oven indicator light
- + Easy wipe clean stainless steel

Available in Stainless Steel and White



EP60SS

EP60WH



Multifunction EM60 series



- + Fully programmable clock includes 'set and forget timer'
- + Eight function full multifunction oven
- + Total usable volume 57LT
- + Closed door grilling
- + Cavity cooling system
- + Double glazed door
- + Easy clean baking tray
- + Grill rack and grill handle
- + Oven indicator light
- + Easy wipe clean stainless steel

Available in Stainless Steel and White



EM60SS

EM60WH



ovens

EC4GSS



EC4GW

EC3WGSS

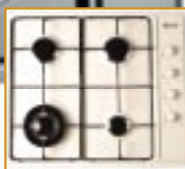

EC3WGW

EC4ESS

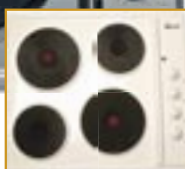

EC4EW

Gas cooktop 60cm series

- + Four gas burner or 3 gas + wok burner
- + One piece hob ideal for easy cleaning
- + One touch electric ignition
- + Non slip trivets
- + Natural Gas or LPG (Jets included)

Available in Stainless Steel and White

| Burner | MJ/HR |
|------------|-------|
| Wok Burner | 12.5 |
| Semi Rapid | 5.9 |
| Quick | 11.0 |
| Auxiliary | 3.5 |
| Voltage | 240V |
| Frequency | 50HZ |
| AMP | 10 |



ECIT60 : OPTIONAL CAST IRON TRIVETS

Electric cooktop 60cm series

- + Sealed EGO elements for easy cleaning
- + Six position temperature control
- + "On" indicator light

Available in Stainless Steel and White

| Plate | Diameter | Load |
|------------------|----------|-------|
| Normal Plate | Ø 145mm | 1000W |
| Normal Plate | Ø 180mm | 1500W |
| Rapid Plate | Ø 145mm | 1500W |
| Rapid Plate | Ø 180mm | 2000W |
| Voltage | 240V | |
| Frequency | 50HZ | |
| Total Rated Load | 6KW | |

Ceran glass 60cm electric cooktop

- + Four burner ribbon elements
- + "On" indicator light
- + Easy cleaning Ceran glass top

Available in Stainless Steel trim

| Elements | Load |
|------------------|----------|
| Ø 145mm | 1200W |
| Ø 180mm | 1800W |
| Voltage | 230-400V |
| Frequency | 50HZ |
| Total Rated Load | 5.8KW |

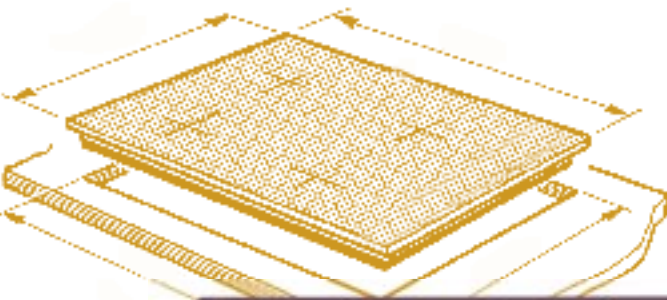

Touch control Ceran glass 77cm electric cooktop

- + Four burner ribbon elements
- + "On" indicator light
- + Safety switch mechanism
- + Locking switch device
- + Easy cleaning Ceran glass top

Available in black bevelled edge

| Elements | Load |
|------------------|------------|
| Ø 145mm | 1200W |
| Ø 210/120mm | 2200W/.75W |
| Ø 260/180mm | 2200W/.75W |
| Voltage | 230-400V |
| Frequency | 50HZ |
| Total Rated Load | 6.0KW |

PVC4HSS

VE77VACAF



cooktops

E5B90SS



E5B90WH



Five Burner 90cm cooktop series

- + Five burner cooktop including fish and wok and three gas burners
 - + One piece hob ideal for easy cleaning
 - + Non slip trivets
 - + One touch electric ignition
 - + Natural Gas or LPG (Jets included)
- Available in Stainless Steel and White

| Burner | Power MJ/HR |
|--------------|-------------|
| Semi Quick | 5.9 |
| Fish | 8.6 |
| Auxiliary | 3.5 |
| T.Crown(wok) | 12.5 |
| Voltage | 240V |
| Frequency | 50HZ |
| AMP | 10 |

ECIT90 : OPTIONAL CAST IRON TRIVETS

E70GCTSS



cooktops



Front control 70cm designer series

- + Five burner cooktop including central wok and four gas burners
- + Non-slip trivets
- + Front control knobs
- + One touch electric ignition
- + One piece hob ideal for easy cleaning
- + Natural Gas or LPG (Jets included)

Available in Stainless Steel



ECIT70 : OPTIONAL CAST IRON TRIVETS

| Burner | Power MJ/HR |
|--------------|-------------|
| Semi Quick | 5.9 |
| Auxiliary | 3.5 |
| Quick | 11.0 |
| T.Crown(wok) | 15.3 |

| | |
|-----------|------|
| Voltage | 240V |
| Frequency | 50HZ |
| AMP | 10 |

EH59WH60



EH59SS60



EH59WH90



EH59SS90



EP11WH60



EP11SS60



60 & 90cm Slideout rangehoods

- + 3 speed motor
- + Separate light function
- + Slide out operation
- + Dishwasher safe mesh filters
- + Carbon filters accessorie (optional)
- + 125mm flue diameter Ø
- + Extraction capacity (60cm) 420m³/HR
- + Extraction capacity (90cm) 550m³/HR
- + One 40W light globe (60cm)
- + Two 40W light globes (90cm)
- + Integratable front panel
- + Ducted or recirculated
- + 240V-50HZ - 10 AMP plug

Available in Stainless Steel and White

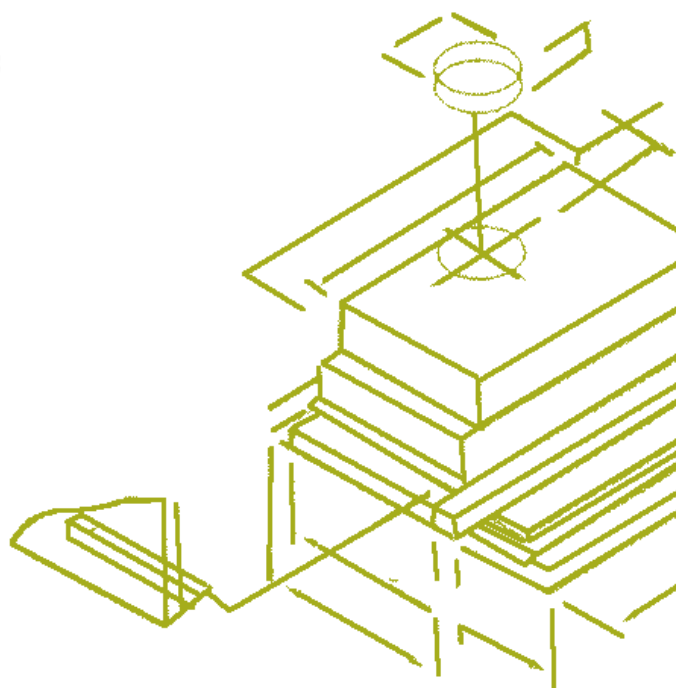

60cm Static rangehoods

- + 3 speed motor
- + Separate light function
- + Dishwasher safe mesh filters
- + Carbon filter accessorie (optional)
- + 125mm flue diameter Ø
- + Extraction capacity 320m³/HR
- + 40W light globe
- + Ducted or recirculated
- + 240V-50HZ - 10 AMP plug

Available in Stainless Steel and White

60 & 90cm Canopy rangehoods

- + Push button front control
- + 3 speed motor
- + Separate light function
- + Dishwasher safe mesh filters
- + Carbon filter accessorie (optional)
- + 125mm flue diameter Ø
- + Extraction capacity 550m³/HR
- + Two 40W light globes
- + Ducted or recirculated
- + 240V-50HZ - 10 AMP plug

Available in Stainless Steel

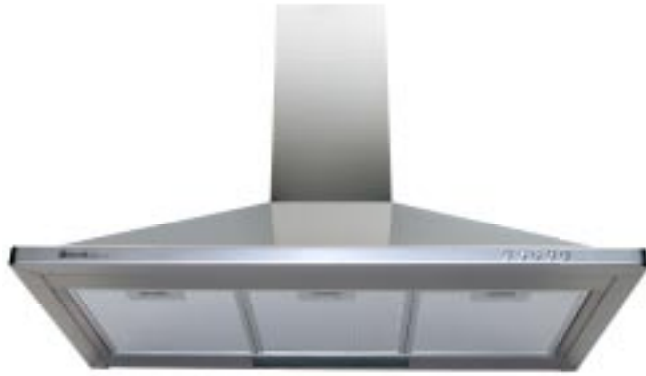

90cm Glass Wall and Island Canopy

- + Push button front control
- + 3 speed motor
- + Separate light function
- + Dishwasher safe mesh filters
- + Carbon filter accessorie (optional)
- + 125mm flue diameter Ø
- + Extraction capacity 750m³/HR
- + Two 50W downlight globes
- + Ducted or recirculated
- + 240V-50HZ - 10 AMP plug

Available in Stainless Steel



EFH88SS60

EFH88SS90

EK83SS

EK71SS



rangehoods

ED60SS



Euro Dishwashers

- + 8 Wash programs
 - + Half load option for smaller loads, reducing water and energy consumption
 - + Economy button
 - + Dimensional spray for hard to clean dishes
 - + Twin sliding cutlery baskets
 - + Overflow protection to prevent flooding
 - + Washing detergent dispenser
 - + ★★ Star Rating
 - + AAA Water Consumption Rating in Australian Standards
 - + Decibel rating - 55DB
 - + Water consumption - 15Litre
- Available in *Stainless Steel and White*

H:850mm **W:**600mm **D:**600mm
Weight:43kg

ED60WH



EDTEL60SS



Euro Electronic Dishwashers

- + Electronic control; including delay timer for a more convenient start time
 - + 5 Wash programs
 - + Half Load option for energy savings
 - + Concealed heating element
 - + Twin sliding cutlery baskets
 - + Overflow protection to prevent flooding
 - + High wash performance with advanced filtration system
 - + Quick height adjustable top basket with slide handle system
 - + Folding bottom rack for pots, pans, bowls and long glasses
 - + ★★ Star Rating
 - + AAA Water Consumption Rating in Australian Standards
 - + Decibel rating - 55DB
 - + Water consumption - 13Litre
- Available in *Stainless Steel and White*

H:850mm **W:**600mm **D:**600mm
Weight:49kg

EDTEL60WH



Rangehood carbon filter

Suitable for rangehoods

CODE EFEH59 - suits EH59 series

CODE EFEP11 - suits EP11 series

CODE EFEFH88 - suits EFH88 series



Oven liner

Suitable for all ovens

CODE EOLIN60 - suits EF60, EP60, EM60 series

CODE EOLIN90 - suits E90MSS series

CODE EFSLIN60 - suits EFS60MSS series

CODE EFSLIN90 - suits ENF90BSS series



Wok support trivet

CODE EWST - suits EFS60MSS series

CODE EWST - suits ENF90BSS series

CODE EWST - suits EEF90MSS series

CODE EWST - suits ECIT70 (cast trivets)

CODE EWST - suits ECIT90 (cast trivets)



Nova freestanding griddle plate

CODE EFSGP - suits ENF90BSS series



Ovens

Elegance 90cm Freestanding Oven - EEF90MSS

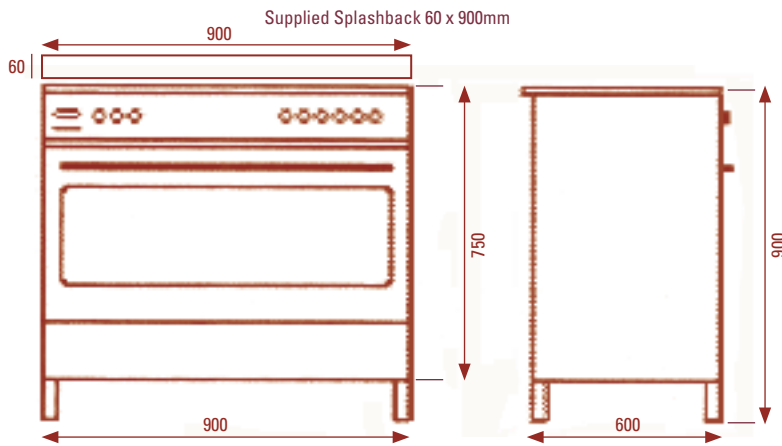

Double Oven - EOSGSS

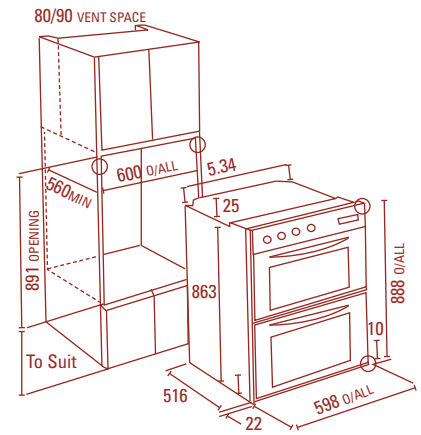

Nova 90cm Freestanding Oven - ENF90BSS

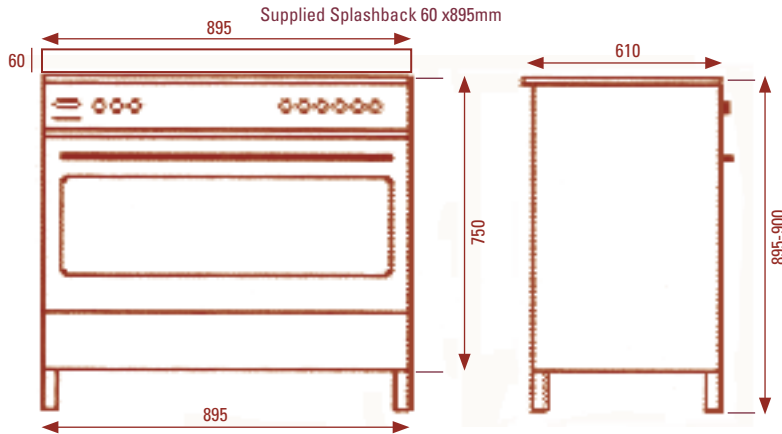

Double Oven - EDOMSS

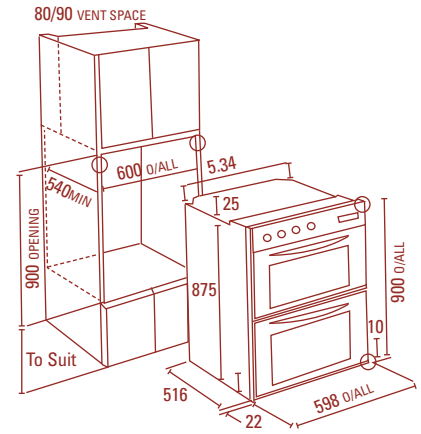

Nova 60cm Freestanding Oven - EFS60MSS

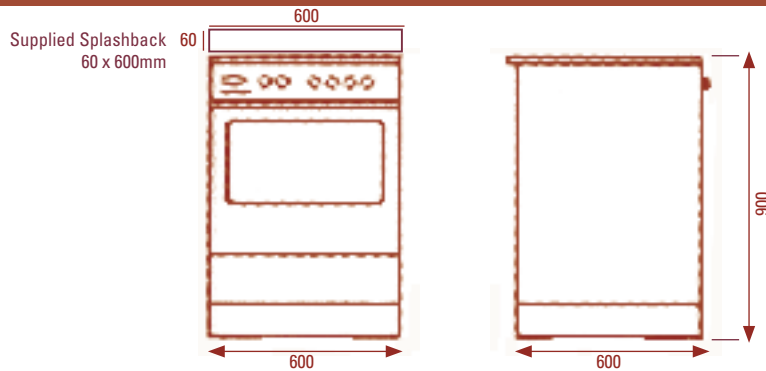

Series EP60, EF60, EM60 Ovens

Under bench installation **

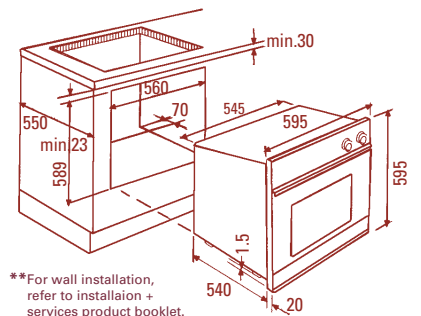

**For wall installation, refer to installation + services product booklet.

90cm Underbench Oven - E90MSS

Under bench installation **

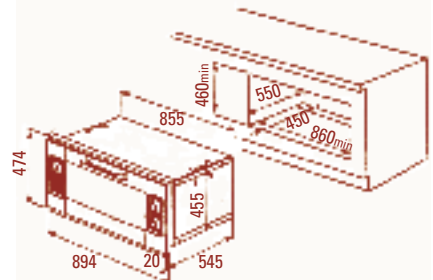

Technical Specifications*

All specifications and product sizes may be varied by the manufacturer without notice. Euro Appliances are not responsible for any errors or omissions. Pictures, specifications and dimensions are for illustration purposes only and cut outs for appliances should only be physical product measurements. All dimensions and information are for indicative use only. Please refer to all technical specifications in product booklet supplied with appliance, prior to installation.

Contact the Customer Care Centre for product support on toll free 1800 440 335.



Cooktops

60cm EC4G, EC3WG, EC4E series

Gas and Electric EGO

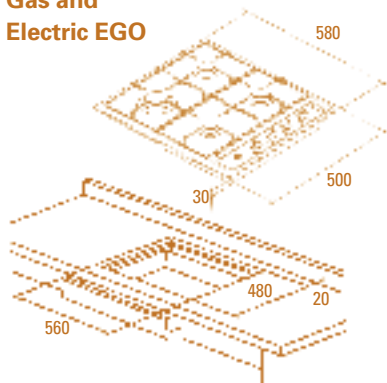

70cm E70GCT Gas series

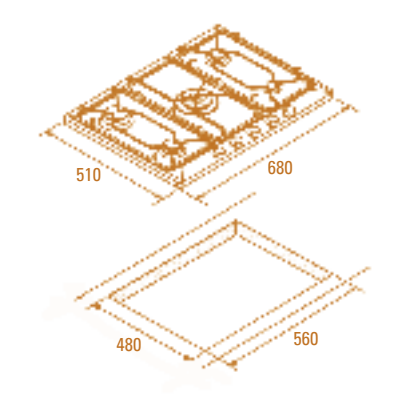

90cm E5B90 Gas series

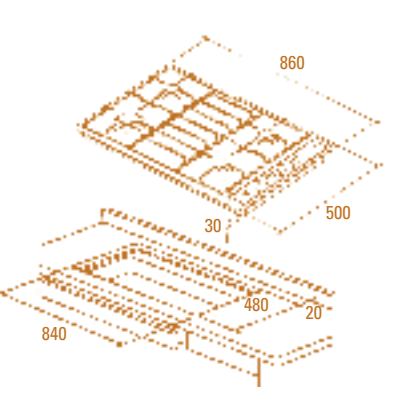

Ceran cooktops

60cm Ceran - PVC4HSS

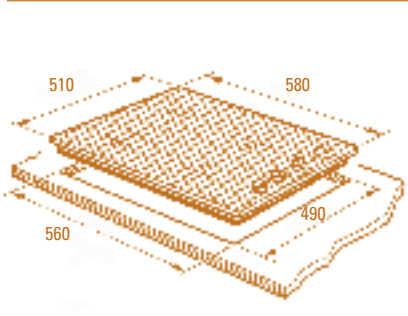

77cm Ceran - VE77VACAF

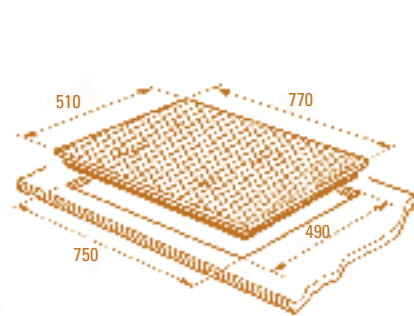

Rangehoods

Canopy EFH88 60/90cm series

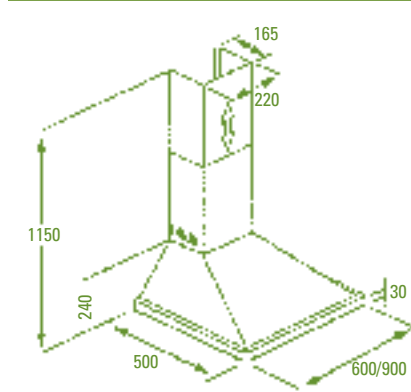

Dishwashers

ED60SS, ED60WH

EDTEL60SS, EDTEL60WH

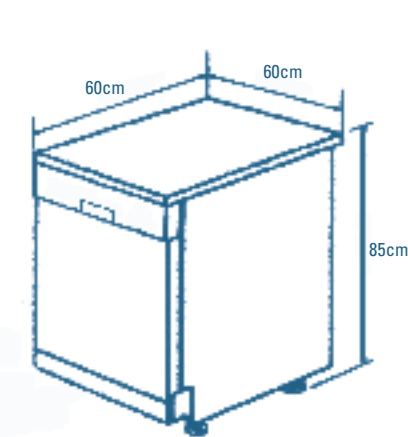

Rangehoods

Slideout - EH59 60/90 series

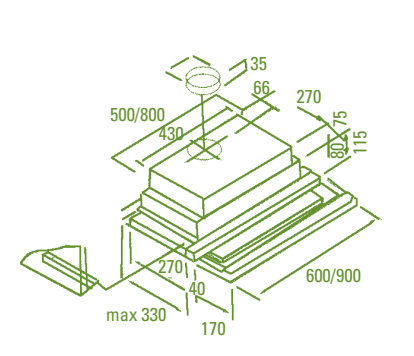

Wall glass - EK83SS series

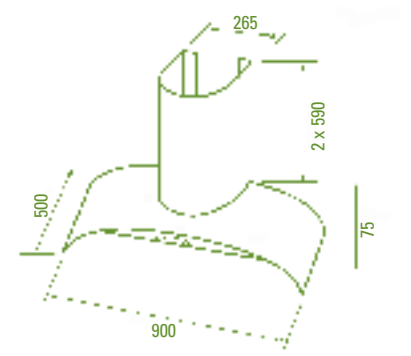

Static - EP11 series

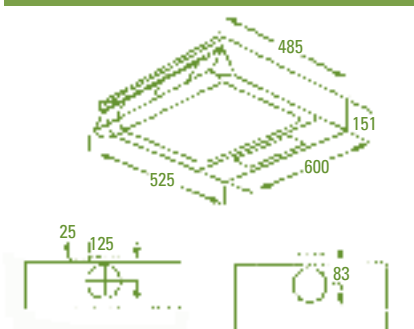

Glass Island - EK71 series

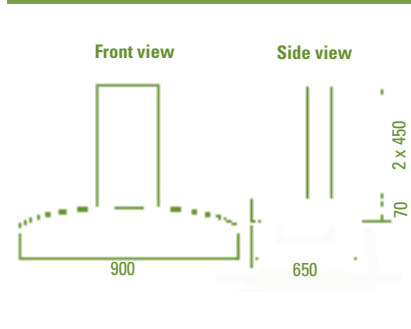

*** Technical Specifications note**
Refer to Technical Specification information on previous page. <<



Belisse 100 850 X 450 X 170mm

Includes

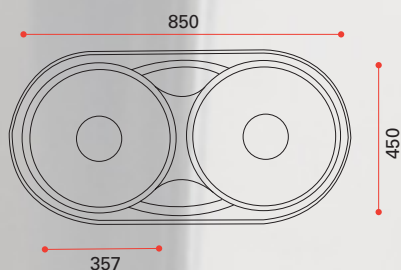
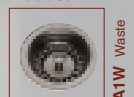

Belisse 200 850 X 450 X 170mm

Includes

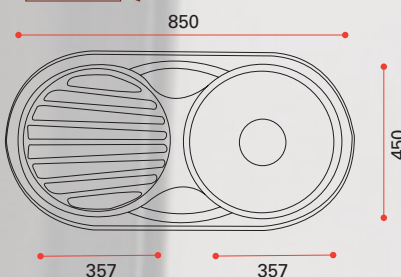

ALL SINKS INCLUDE BASKET WASTE



TMB14 Bagni Mixer

Euro Sinks is a product of
euro appliances

Product Support and Service
 Contact the customer care centre
 toll free on **1800 440 335**

HEAD OFFICE
 + 6 Pattinson Road
 Newton SA 5074
 T] 08 8165 1012
 F] 08 8165 1018
 E] admin@eurostyle.com.au
 W] www.euroappliances.com.au



euro sinks
quality, design, perfect finish



Grande 010 780 X 480 X 170mm

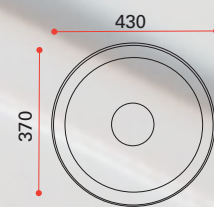
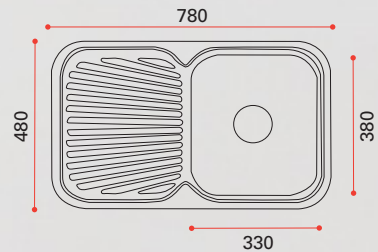

430 X 170mm **Onri 500**



Grande 020 980 X 480 X 170mm

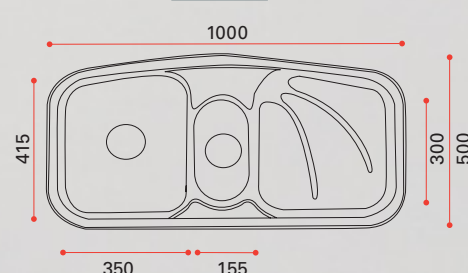
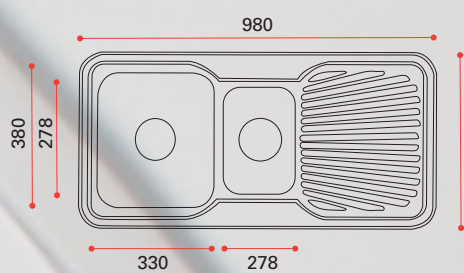

1000 X 500 X 170mm **Careca 1000**



Grande 030 1180 X 480 X 170mm

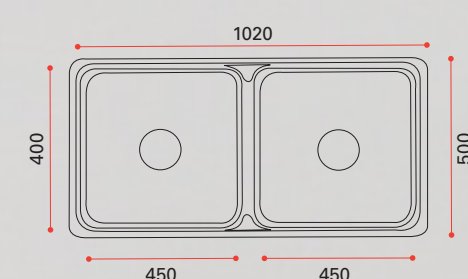
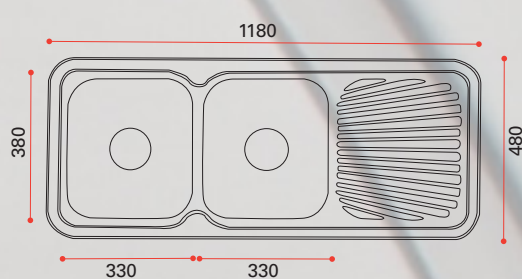

1020 X 500 X 190mm **Riva 001**



Grande 040 1380 X 480 X 170mm

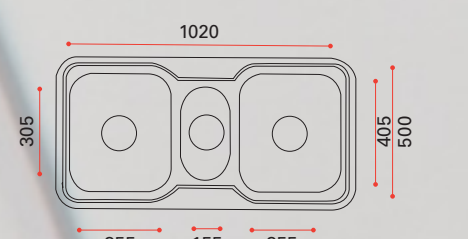
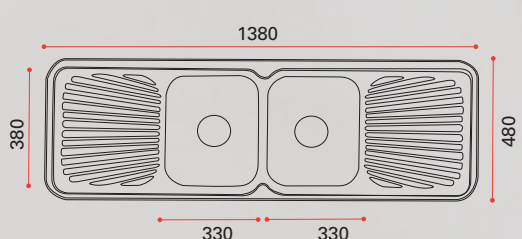

1020 X 500 X 180mm **Anton 410**

ALL SINKS INCLUDE BASKET WASTE

ALL SINKS INCLUDE BASKET WASTE



All Euro Appliances
are under a **full
two year warranty**

TWO YEAR WARRANTY covering parts and labour.

From the date of purchase the
Euro Appliances Warranty protects
the consumer with rectification free
of charge of any faulty arising from
defective materials or components.

**Incorrect installation of any
product will void all warranty.**

Product Support and Service

Contact the customer care centre

toll free on **1800 440 335**

 **euro** appliances

HEAD OFFICE + 6 Pattinson Road Newton SA 5074

T] 08 8165 1012 **F**] 08 8165 1018 **E**] admin@eurostyle.com.au



Doug Smith Spares:
1/28 Martha St Granville Ph: (02) 8868 6700. 67 Grandview St Pymble Ph:(02) 9449 7655

